

INSTALL 12-14 INSULATION BAGS OR MORE IF REQ'D. BAGS SHALL BE FILLED WITH POLYURETHANE FOAM "PEANUTS". SECURELY HEAT SEAL OR TAPE EACH END OF EACH BAG. DOUBLE BAG EACH BAG UNIT. PLACE BAGS AROUND THE AIR RELEASE VALVE. CONTRACTOR SHALL PROVIDE PROTOTYPE OF INSULATING BAG FOR APPROVAL BY ENGINEER BEFORE PROVIDING BAGS FOR PROJECT. USE CONSOLIDATED PLASTIC CO. INC. (1-800-362-1000) #90349KA 4-MIL. 18"X20" POLY BAGS OR APPROVED EQUAL. COSTS OF BAGS AND "PEANUTS" TO BE INCLUDED IN "WATER AIR RELEASE VALVE" BID ITEM.

INLAND FOUNDRY CO. INC. #713 FROST PROOF MANHOLE RING AND COVER OR APPROVED EQUAL.

PRECAST 48" I.D. MANHOLE. WITH PRECAST TRAFFIC RATED TOP SLAB

1" SERVICE CONNECTION AS REQUIRED SEE TECHNICAL SPECIFICATIONS

NOTCH MANHOLE AS REQUIRED OVER PIPE. PROVIDE 4-INCH MIN. CLEARANCE.

AS REQ'D.

48" MIN.

VARIABLES
30" MIN.

G.I.P.

SLOPE UP

1" HDPE

1" BALL VALVE WITH HAND OPERATOR

12" MIN. 3/4"-Ø CRUSHED ROCK

4" MAX.

UNION

6" MIN.

3' MIN.

VARIABLES

1" G.I.P.

SLOPE

UNION

3/4" WIDE 5.5. BANDS

CAULK WATER TIGHT

REDHEAD ANCHOR BOLTS AS REQ'D.

4x4 PRESSURE TREATED BLOCK

APCO NO. 143C OR APPROVED EQUAL

4x4 PRESSURE TREATED WOOD POST
SCREENED AIR VENT, CLAY AND BAILEY MODEL CB300-1, OR EQUAL

3/4" WIDE 5.5. BANDS AS REQ'D.

EXISTING GROUND

3' MIN.

1" HDPE

3-90° G.I.P. ELBOWS

12" MIN.

4x4 WOOD POST

TOP VIEW

WATER AIR RELEASE MANHOLE

INSTALL BARRICADE. 4 REQ'D SEE BARRICADE DETAIL

WOOD POST

WATER AIR RELEASE VALVE

N.T.S.

PLAN DETAIL

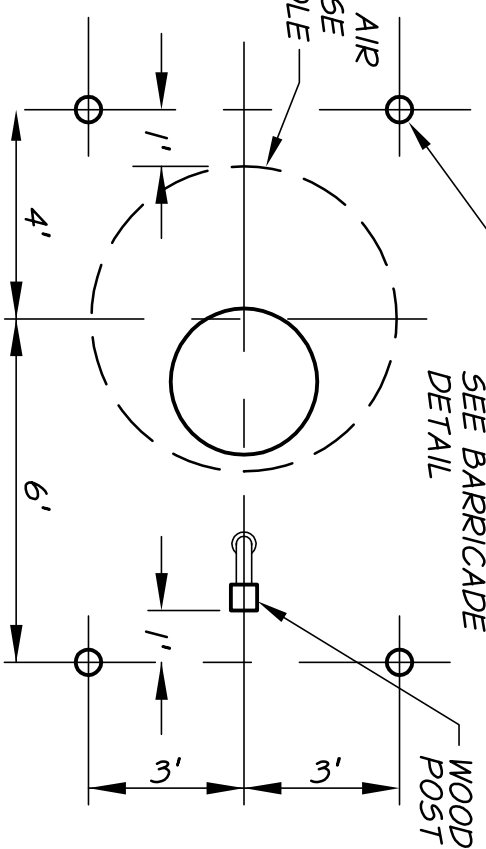

REVISION

DATE

CITY OF
UNION
OREGON

STANDARD WATER DETAILS

WATER AIR RELEASE VALVE

FIGURE

W-11