

## VALVE BOX DETAIL

N.T.S.

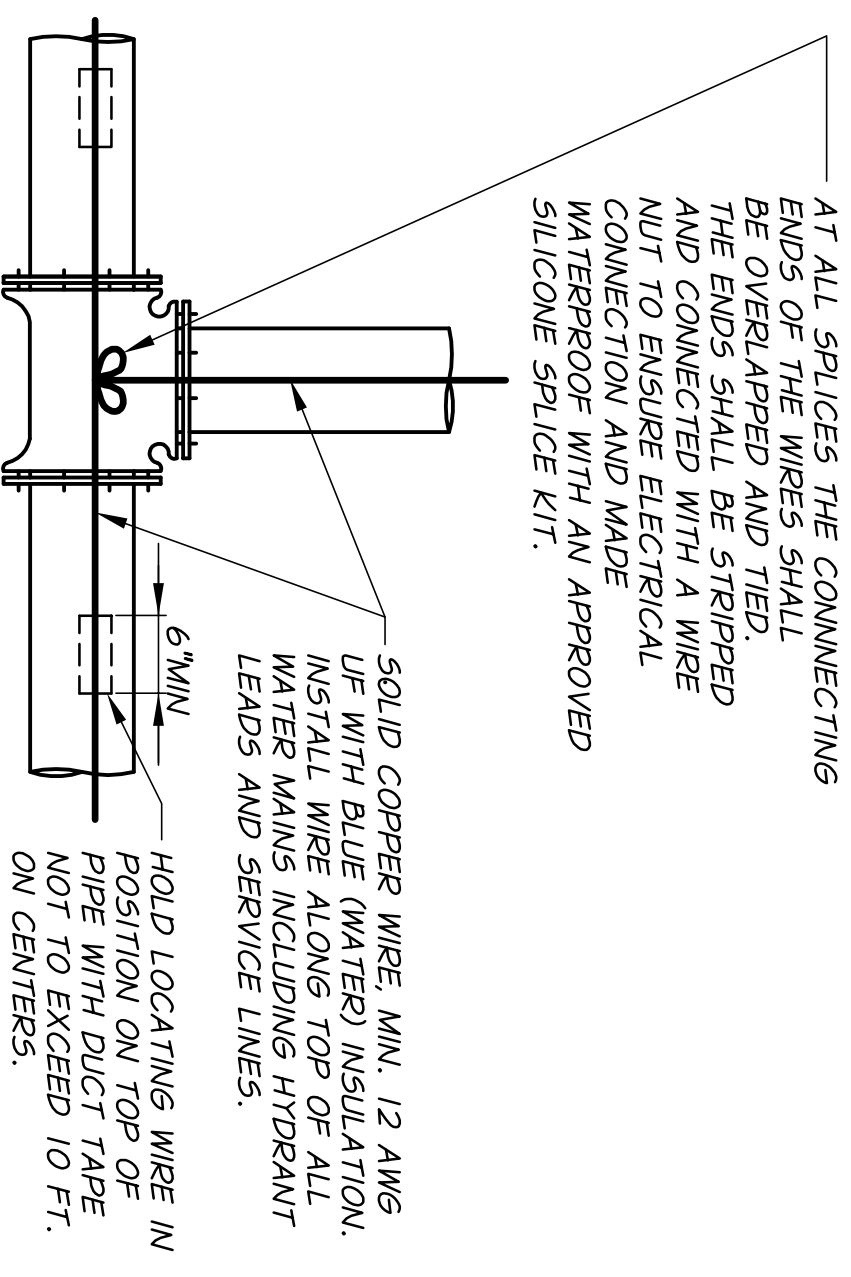

## CONTINUOUS LOCATING WIRE DETAIL

N.T.S.

| REVISION        | DATE  |
|-----------------|-------|
| GENERAL UPDATES | 12/06 |
|                 |       |
|                 |       |

CITY OF  
UNION  
OREGON

STANDARD WATER DETAILS  
VALVE BOX AND CONTINUOUS  
LOCATING WIRE DETAIL

FIGURE  
**W5**